

*Oshkosh*  
***Police***

Crime Prevention



# HOME SECURITY HANDBOOK

CRIME PREVENTION UNIT

420 JACKSON STREET

920-236-5742



FOR FURTHER INFORMATION OR ADDITIONAL COPIES OF THIS PUBLICATION,

PLEASE CALL (920) 236-5742 OR EMAIL [JNICHOLS@CI.OSHKOSH.WI.US](mailto:JNICHOLS@CI.OSHKOSH.WI.US) OR

YOU CAN WRITE TO: OSHKOSH POLICE DEPARTMENT

CRIME PREVENTION UNIT

420 JACKSON ST

OSHKOSH, WI 54901

SUMMER 2016

THIRD EDITION

EDITOR: JOSEPH NICHOLS

# NEIGHBORHOOD WATCH

Our nation is built on the strength of our citizens. Every day, we encounter situations calling upon us to be the eyes and ears of law enforcement. Not only does neighborhood watch allow citizens to help in the fight against crime, it is also an opportunity for communities to bond through service. The Neighborhood Watch Program draws upon the compassion of average citizens, asking them to lend their neighbors a hand.

-National Sheriff's Association

# TABLE OF CONTENTS

4	LETTER FROM THE CHIEF OF POLICE	19	GRAFFITI
5	FORWARD AND INTRODUCTION	20	PERSONAL PROTECTION
6-11	HOME SECURITY SURVEY	20	PERSONAL PROTECTION VEHICLES
12	CONCEPTS OF BURGLARY PREVENTION	20	PERSONAL PROTECTION PARKING LOTS
13	PROTECTING THE HOMES INTERIOR	21	PERSONAL PROTECTION WALKING OR RUNNING
13	OPERATION ID	21	PERSONAL PROTECTION AT HOME
13	REMOVE EXCESS CASH OR VALUABLES FROM YOUR HOME	21	PERSONAL PROTECTION EMERGENCY NUMBERS
13	INSTALL A SAFE IN THE HOME	21-22	PERSONAL PROTECTION BURGLAR IN THE HOME
13	INSURANCE	22	PERSONAL PROTECTION ON VACATION
13	DON'T WELCOME BURGLARS BY PHONE	23	PRESCRIPTION MEDICATIONS
14	PROTECTION AGAINST ENTRY	24	NEIGHBORHOOD WATCH
16	KEY CONTROL	23	OSHKOSH POLICE DEPARTMENT PHONE NUMBERS
16	ENTRANCE/EXIT DOORS AND LOCKS	23	OSHKOSH POLICE DEPARTMENT WEBSITE
17	GLASS DOORS/PATIO DOORS	26	OPERATION ID RECORD
17	WINDOWS-DOUBLE HUNG	27	SIGNS OF A DRUG HOUSE
18	WINDOWS-BASEMENT		
18	WINDOWS-CASEMENT		
18	GARAGE DOORS		
18	ALARMS		
18	DOGS		
18	PROTECTING THE HOMES EXTERIOR		
19	LIGHTS		
17	LANDSCAPING		
17	FENCING		





City of Oshkosh  
Police Department

420 Jackson Street  
Oshkosh, WI 54901  
Tel: 920-236-5720  
Fax: 920-236-5087  
sgreuel@ci.oshkosh.wi.us

---

PROFESSIONALISM • PRIDE • INTEGRITY • TEAMWORK

Dean M. Smith  
Chief of Police

The Oshkosh Police Department provides community based Team Policing with a primary goal of building a safe and strong community. The operational philosophy of our organization is to be community based, problem resolution focused and data driven. Our crime prevention strategies are designed to reduce crime and the fear of crime in our community.

Crime occurs when there is a motivated offender willing to victimize another person or entity at a certain place or location. Crime can be reduced or eliminated if one of those elements is removed or prevented from occurring. Police officers are dedicated in their effort to prevent crime and hold those that do commit crimes accountable for their actions. We are most effective when we work together in partnership with our community stakeholders.

This handbook was developed to assist you in taking action to prevent or reduce the likelihood of being a victim of crime. You can become less of a target of burglary or theft if you follow the recommendations for securing your home, business, or vehicle. You can reduce the likelihood of victimization by following the recommendations on personal protection as outlined in this handbook. Consider joining or starting a Neighborhood Watch Group in the area that you live or work. Get to know the Team Officers in your area and don't be hesitant on reporting any suspicious activity. Together, we can work as a team to promote public safety and enhance the quality of life in our community through innovative policing and community partnerships.

For further assistance...call your Team Officer, visit us on the internet at [www.oshkoshpd.com](http://www.oshkoshpd.com), or contact our Crime Prevention Officer at (920) 236-5742.

Dean M. Smith

Chief of Police

Oshkosh Police Department

## FOREWORD

The Oshkosh Police Department's has focused its attention to Team Policing. This concept is new to the Oshkosh Police Department, but not a new concept in policing. This policing concept places an officer into one specific area for a year, thereby giving the officer the opportunity to learn about the area's needs, crime patterns, and gives the officer a sense of oneness to the area.

Neighborhood Watch is a very large part of Crime Prevention in the City of Oshkosh. Sir Robert Peel, the founder of the modern day police force, had nine policing strategies. One of his nine strategies was this: The Public are the Police; the Police are the Public. Very simply stated, we are all in this together when fighting crime. Neighborhood Watch is an excellent opportunity for neighbors to unite and work together to prevent and report crimes. Study after study throughout the world shows that a neighborhood that has a watch has a reduction in crime, especially burglary. If your block doesn't have a Neighborhood Watch, please consider starting one, even if there is no current crime in your neighborhood.

The Crime Prevention Unit is working hard to develop a lasting partnership with the neighborhoods of the city in preventing crime and in improving the quality of life for the citizens of Oshkosh. The Crime Prevention Unit works with various organizations such as TRIAD, TRICOM, SALT, Neighborhood Watch, and many other community groups in identifying problems in an area and helping to alleviate the problems.

A criminal is always looking for an OPPORTUNITY to commit a crime. Do not give the criminal the opportunity to commit a crime. Safeguard your home, family, and neighborhood and see your area flourish in quality of life issues. Report all suspicious activity, persons, and vehicles in and around your home to the police and to your neighbors. The person with the greatest power to prevent crime in your neighborhood is YOU!

## INTRODUCTION

Over the years, many millions of dollars have been stolen from homes and businesses in Oshkosh by criminals. In order to stop this trend, citizens and police must stand together to prevent crime in Oshkosh.

Each of us feels the impact of burglary or theft, directly or indirectly, through the fact that your home may have been burglarized or your property in your vehicle was stolen, the constant reports of these crimes, or the increased insurance premiums or depreciation and decline of the neighborhoods.

Burglary and theft continue to be one of the most common types of crimes, yet these crimes are one of the most preventable.

After reading this handbook and implementing some of the suggested techniques in securing your home, your family, or other property, pass it on to your neighbors, family or friends. Better yet, start a Neighborhood Block Watch Group in your area and begin seeing your neighborhood become cohesive in the fight against crime.

With you providing the best defense to crime prevention for your home and neighborhood, you and your family will enjoy a better quality of life, as well as your neighborhood.

The Oshkosh Police Department thanks you for reading this handbook and participating in a campaign in stopping crime in our neighborhoods.

# NATIONAL NEIGHBORHOOD WATCH PROGRAM

## HOME SECURITY INSPECTION CHECKLIST



An important step in preventing home burglary and other crimes is to make sure that a residence is as secure as possible. A careful inspection by someone trained to observe security precautions can indicate features which would make entry easy — or difficult — for a prospective burglar.

Chances are good that home security can be improved. Take a hard look at entry points in your residence and determine what steps can reduce vulnerability.

A security inspection begins at the front door and goes on to include side and rear doors, windows, locks, lights, and landscaping. Checks in the orange column of this checklist indicate security weaknesses or hazards that require attention.

This survey may be used by law enforcement professionals or others trained in crime prevention. Neither the inspector, the local law enforcement agency, nor NSA have any liability to you other than to use our best judgment in this inspection and these recommendations.

We appreciate the opportunity to be of assistance to you in the community's fight against crime. We urge you not only to take steps to make your own residence safer, but also to become active in a Neighborhood Watch program for the benefit of your entire community.

FOR FURTHER INFORMATION YOU MAY CALL:



OSHKOSH POLICE  
DEPARTMENT  
CRIME PREVENTION UNIT  
(920) 236-5742

This form was produced and distributed by  
THE NATIONAL SHERIFFS' ASSOCIATION  
in cooperation with your  
local law enforcement agency

# HOME SECURITY SURVEY

Before reading this book, you should conduct a security survey of your home. To do this, you will need to use this checklist to point out weaknesses to your home's security. Mark the question with a Yes or No or N/A. Recommendations are included to enhance the security of your home. **DO NOT GIVE THE THIEF OR BURGLAR THE OPPORTUNITY TO MAKE YOU A VICTIM OF CRIME!**

<b>DOORS</b>	<b>Y</b>	<b>N</b>	<b>RECOMMENDATIONS</b>
ARE DOORS MADE OF SOLID CORE MATERIAL?	<input type="checkbox"/>	<input type="checkbox"/>	DOORS MADE OF SOLID CORE PROVIDE BETTER SECURITY
DO YOU HAVE THE PROPER LOCKS INSTALLED? (DEADBOLT)	<input type="checkbox"/>	<input type="checkbox"/>	DEADBOLTS ON ALL ENTRY DOORS DEADBOLT AT LEAST 1" MIN THROW USE OF A KEY SYSTEM ADVISED 3" SCREWS TO SECURE STRIKE PLATE
SECURITY LIGHT BY ALL ENTRY/EXIT DOORS?	<input type="checkbox"/>	<input type="checkbox"/>	MINIMUM 60 WATT BULB BY ENTRANCES
DO YOU LOCK ALL YOUR DOORS AT NIGHT OR WHEN YOU ARE NOT HOME? (HOUSE AND GARAGE)	<input type="checkbox"/>	<input type="checkbox"/>	LOCK ALL YOUR DAYS, DAY OR NIGHT WHETHER YOU ARE PRESENT OR NOT
DO YOU KEEP A SPARE KEY OUTSIDE?	<input type="checkbox"/>	<input type="checkbox"/>	DO NOT LEAVE A KEY OUTSIDE OR HIDDEN KEEP A KEY AT YOUR NEIGHBORS HOME
ARE ALL OF YOUR PATIO DOORS OR OTHER ENTRANCES EQUIPPED WITH LOCKS OR A WAY OF SECURING THEM?	<input type="checkbox"/>	<input type="checkbox"/>	SECURE ALL POSSIBLE ENTRANCES TO YOUR HOME WITH PROPER LOCKS OR USE A SECURITY BAR ON PATIO DOOR
DOORS SWINGING OUT HAVE HINGES PINNED OR HAVE NON REMOVABLE PINS?	<input type="checkbox"/>	<input type="checkbox"/>	YOUR EXTERIOR DOORS SHOULD BE HINGED ON THE INSIDE. IF NOT, CORRECT



## SECURITY SURVEY (CONT)

	<u>Y</u>	<u>N</u>	<u>RECOMMENDATIONS</u>
IS THE GARAGE DOOR SECURED PROPERLY?	<input type="checkbox"/>	<input type="checkbox"/>	INSTALL LOCKS ON ENTRANCE DOOR AND GARAGE DOORS
<b><u>WINDOWS</u></b>			
DO ALL OF YOUR WINDOWS HAVE LOCKS?	<input type="checkbox"/>	<input type="checkbox"/>	INSTALL LOCKS ON ALL WINDOWS
DO YOU KEEP YOUR WINDOWS LOCKED WHEN THEY ARE SHUT?	<input type="checkbox"/>	<input type="checkbox"/>	LOCK ALL WINDOWS WHEN NOT IN USE.
IF WINDOWS ARE LEFT OPEN FOR VENTILATION, CAN THEY BE SECURED?	<input type="checkbox"/>	<input type="checkbox"/>	SECURE WINDOWS THAT ARE LEFT OPEN FOR VENTILATION
DO YOU HAVE SECURE LOCKS ON GARAGE WINDOWS?	<input type="checkbox"/>	<input type="checkbox"/>	PLACE LOCKS ON GARAGE WINDOWS
DO YOU HAVE CURTAINS/DRAPES ON WINDOWS?	<input type="checkbox"/>	<input type="checkbox"/>	WHEN OUT OF THE HOUSE, OPEN THE CURTAINS/DRAPES
<b><u>SAFE PRACTICES</u></b>			
IS ALL OF YOUR VALUABLES MARKED WITH YOUR DRIVERS LICENSE NUMBER AND DO YOU KEEP A LIST OF YOUR VALUABLES?	<input type="checkbox"/>	<input type="checkbox"/>	ENGRAVE ALL YOUR VALUABLES WITH YOUR DRIVERS LICENSE NUMBER AND KEEP A LIST OF VALUABLES IN A SAFE PLACE.
DO YOU KEEP EXCESS CASH IN THE HOME?	<input type="checkbox"/>	<input type="checkbox"/>	PLACE EXTRA CASH IN A FINANCIAL INSTITUTION.
DO YOU PUBLICLY DISPLAY VALUBABLES?	<input type="checkbox"/>	<input type="checkbox"/>	DO NOT SHOW AND TELL YOUR VALUABLES

## SECURITY SURVEY (CONT)

	<u>Y</u>	<u>N</u>	<u>RECOMMENDATIONS</u>
ARE MOTION SENSOR LIGHTS INSTALLED AROUND THE HOME?	<input type="checkbox"/>	<input type="checkbox"/>	INSTALL MOTION SENSOR LIGHTS IN AREAS THAT ARE DARK
IS YOUR HOME ADDRESS VISIBLE FROM THE STREET?	<input type="checkbox"/>	<input type="checkbox"/>	INSTALL HOUSE NUMBERS THAT ARE CLEAR FROM THE STREET
DOES YOUR FAMILY KNOW WHAT TO DO IN CASE OF FIRE? BURGLAR? OTHER EMERGENCY?	<input type="checkbox"/>	<input type="checkbox"/>	MAKE A HOME SAFETY PLAN FOR FIRES, BURGLARS, TORNADOES, AND OTHER EMERGENCIES AND PRACTICE THE PLANS
<b><u>VEHICLES</u></b>			
DO YOU LOCK YOUR CAR DOOR AT ALL TIMES WHEN IN OR OUT OF THE VEHICLE?	<input type="checkbox"/>	<input type="checkbox"/>	LOCK YOUR VEHICLE DOORS AT ALL TIMES WHETHER YOU ARE IN OR OUT OF THE VEHICLE
DO YOU REMOVE ALL OF YOUR VALUABLES FROM YOUR CAR OR LOCK THEM IN THE TRUNK WHEN YOU ARE NOT IN THE VEHICLE?	<input type="checkbox"/>	<input type="checkbox"/>	REMOVE ALL YOUR VALUABLES WHEN YOU ARE NOT IN YOUR VEHICLE
DO YOU LEAVE VALUABLES ON THE FRONT SEAT WHEN DRIVING?	<input type="checkbox"/>	<input type="checkbox"/>	PLACE YOUR VALUABLES ON THE FLOOR OR IN THE TRUNK AND OUT OF VIEW.
DO YOU PARK IN AN AREA THAT IS CLOSE TO THE ENTRANCE/EXITS AND WHERE IT IS WELL LIT?	<input type="checkbox"/>	<input type="checkbox"/>	PARK YOUR VEHICLE AS CLOSE TO THE ENTRANCE/EXIT OF A BUILDING AND WHERE THERE IS ADEQUATE LIGHTING.

## HOME SECURITY SURVEY (CONT)

	<u>Y</u>	<u>N</u>	<u>RECOMMENDATIONS</u>
<b><u>LANDSCAPING</u></b>			
ARE YOUR TREES AND SHRUBS NEATLY TRIMMED?	<input type="checkbox"/>	<input type="checkbox"/>	TRIM YOUR TREES AT LEAST 6 FEET HIGH FROM THE GROUND AND BUSHES TO A LEVEL OF 2 FEET FROM THE GROUND AND AWAY FROM WINDOWS
IS YOUR YARD NEATLY MAINTAINED?	<input type="checkbox"/>	<input type="checkbox"/>	MOW THE LAWN, CLEAN UP THE LEAVES, GARBAGE FROM AROUND THE YARD.
IS YOUR FENCE SEE THROUGH OR SOLID?	<input type="checkbox"/>	<input type="checkbox"/>	FENCES THAT ARE SEE THROUGH PROVIDE NO COVER FOR A THEIF.
IF YOU HAVE BUSHES NEAR YOUR HOME, ARE THEY A HAVEN FOR CRIMINALS TO THAT HAS LOW HIDE?	<input type="checkbox"/>	<input type="checkbox"/>	CONSIDER PLANTING HOSTILE VEGETATION GROWTH SUCH AS ROSES, BARBERRY, ETC TO ELIMINATE HIDING PLACES
<b><u>VACATION</u></b>			
WHEN PLANNING A TRIP, DO YOU ARRANGE FOR THE MAIL, PAPER, AND OTHER DELIVERIES TO STOP?	<input type="checkbox"/>	<input type="checkbox"/>	CALL THE NEWSPAPER, US MAIL, OTHER DELIVERIES AND TEMPORARILY PLACE A HOLD
DO YOU NOTIFY YOUR NEIGHBOR, FAMILY AND FRIENDS TO WATCH THE HOUSE?	<input type="checkbox"/>	<input type="checkbox"/>	ASK YOUR NEIGHBOR, FAMILY, AND FRIENDS TO WATCH OVER YOUR HOUSE AND MAKE IT LOOK "LIVED

## HOME SECURITY SURVEY (CONT)

	<u>Y</u>	<u>N</u>	<u>RECOMMENDATIONS</u>
DO YOU MAKE YOUR HOME LOOKED LIVED IN BY USING A TIMER FOR LIGHTS, HAVING SOMEONE CUT THE GRASS, AND USE YOUR DRIVEWAY?	<input type="checkbox"/>	<input type="checkbox"/>	ASK SOMEONE TO CUT YOUR LAWN, USE TIMERS FOR LIGHTS, AND ASK YOUR NEIGHBOR TO USE YOUR DRIVEWAY
IS YOUR HOME NUMBER OF SUFFICIENT SIZE SO THAT IT CAN BE SEEN BY EMERGENCY PERSONNEL IF THEY NEED TO RESPOND TO YOUR HOME?	<input type="checkbox"/>	<input type="checkbox"/>	MAKE SURE THAT PER ORDINANCE, YOUR HOUSE NUMBERS ARE DISPLAYED PROPERLY ON THE FRONT OF YOUR HOME
<b><u>PRESCRIPTION MEDICATIONS</u></b>			
ARE ALL YOUR PRESCRIPTION MEDICATIONS PROPERLY SECURED AND ACCOUNTED FOR?	<input type="checkbox"/>	<input type="checkbox"/>	PROPERLY SECURE ALL YOUR MEDICATIONS IN ORDER TO KEEP THEM SAFE FROM CHILDREN AND TO KEEP THEM SAFE FROM THEFT. THE NEW DRUG PROBLEM IS PRESCRIPTION MEDICATIONS. LOCK THEM UP AND KEEP COUNT OF ALL YOU MEDICATIONS
WHEN YOUR MEDICATIONS OR PRESCRIPTIONS ARE NO LONGER USED OR EXPIRED, DO YOU THROW THEM IN THE GARBAGE OR DOWN THE DRAIN?	<input type="checkbox"/>	<input type="checkbox"/>	DO NOT DISCARD YOUR OLD MEDICATIONS OR PRESCRIPTIONS IN THE GARBAGE OR DOWN THE DRAIN. YOU MAY BE CONTAMINATING THE WATER SUPPLIES. DISCARD ALL UNUSED OR EXPIRED MEDICATIONS AND PRESCRIPTIONS AT AN APPROVED DRUG DISPOSAL COLLECTION BIN OR WHEN A LOCAL MEDICAL FACILITY HAS A COLLECTION DAY.

## CONCEPTS OF BURGLARY PREVENTION

Prevention involves five concepts: Deter, Deny, Delay, Detect, and deceive. Our crime prevention program is based upon appropriate action to implement these five concepts. The following is an all too common result in that a home owner overlooks prevention concepts in favor of a particular preventative step.

The home owner went to considerable expense to install the finest windows and door locks, thereby implementing one step to address the concept of delay. The resident, secure in the knowledge that their residence was now safe, departed on a short vacation without letting his family, friends or neighbors know that they were leaving.

He returned to find a burglar had simply broke a window to gain entry. The window was concealed from public view and was in a dark area where no lights were installed. The burglar took many expensive items that had no identifying marks. The resident concluded that crime prevention was a failure.

In this example, the homeowner concentrated on only one concept, denial. What led to the burglary was the failure of the homeowner to implement other crime prevention concepts. Consider how different this situation could have been had the following concepts and preventative steps been followed.

Deterrence: Placing valuables in a secure location such as a wall safe, financial institution, etc.

Delaying: Installing locking mechanisms on the windows.

Detecting: Installing an alarm system in the home; or the neighborhood had a neighborhood watch program.

Deceiving: Placing timers on lights, had neighbors pick up mail and keeping the yard look tidy.

These five preventative steps can also aid in apprehension of a criminal. The longer the time for a burglar or a thief is denied entry into a home, garage, or car, the greater the chances are that a neighbor may observe or hear the subject and call the police.

You cannot make your home completely burglar or theft proof; but you can make entry into your personal property so difficult that a criminal will go elsewhere to find an easier target. The more crime prevention steps you take, the greater your security.

# PROTECTING THE HOME'S INTERIOR

## **MARKING AND RECORDING YOUR PROPERTY—OPERATION I.D.**

Marking your valuables and keeping a record of your possessions is one way you can reduce the risk of burglary in Oshkosh. This program is known as Operation I.D.

Using an Operation I. D. marking pen or an engraver, you place your driver's license on your valuables. Inscribe your driver's license number preceded by the letters "WI" on all your valuables such as appliances, guns, cameras, lawn equipment, and anything else you consider valuable. These numbers can be placed on the base or rear portion of the item without marring the appearance of the item. Some items that are too small, such as jewelry, that cannot be marked, should be photographed. Extremely valuable jewelry should be appraised and the photo and description should be recorded.

Once you have marked your valuables, you should record these items in the back of this handbook and place a copy of the record in a safe, secure place. Save your receipts and serial numbers from your more valuable items and keep them with the inventory list. If you lose an item or items due to a criminal act, act of nature, or any other type of loss you may encounter, you will have a record of these items that will ensure proper recovery and/or replacement. Update your inventory list at least once a year to make sure newly bought items are listed. Burglar's avoid homes where an identification system is in force. Contact the Crime Prevention Office at 236-5742 to learn how you can mark your items. You can list your items on Page 26 of this handbook.

## **REMOVE EXCESS CASH FROM HOME**

If, despite all precautions, your home is still burglarized, do not give the burglar a bonus by keeping excess cash or expensive jewelry in the home. Place your excess cash in a financial institution or a safe deposit box along with your jewelry.

## **INSTALL A SAFE OR SECURITY CLOSET FOR VALUABLES**

A secondary barrier, such as a safe or security closet can be created to place valuables such as jewelry, cash, cameras, or other valuables in. For a security closet, the door should be solid core equipped with a cylinder deadbolt lock. The hinges of the door should be pinned.

## **INSURE AGAINST THEFT**

All homeowner's policies provide basic economic protection against burglary and other types of theft, regardless if you own a house or rent an apartment. Special policies designed for mobile home owner's and condominium unit owners serve the same purpose. If you don't already have a policy, purchase one without delay.

## **DON'T WELCOME BURGLARS BY TELEPHONE**

Burglar's today still try to find out if anyone is home by phoning. If you get several suspicious phone calls or no one is on the other end of the phone calls, you may want to report this to the police, who in turn can subpoena phone records to see who is calling. Remind your family members, especially children, that if someone calls, don't tell the caller that they are home alone or that the parents are not there. Also, do not give out any personal information over the phone. If you use an answering machine, do not leave messages stating that you will be away for a prescribed time. Do not place your full name on the mailbox, door, or apartment building. Do not give the criminal the opportunity to know who you are.

## **SOCIAL MEDIA AND VACATIONS—DON'T GIVE IT AWAY THAT YOU ARE NOT HOME!**

When you are on vacation, share your vacation photos and memories after you get home.

Posting photos and memories of your vacation when you are away from home is inviting a criminal to your home. Many have experienced the unfortunate burglary or theft when returning home as a criminal was watching what you were doing on social media sites such as Face Book or Instagram.

# PROTECTION AGAINST ENTRY

Did you know that over 75% of the burglaries occur to the rear door or other rear entrance to a residence? So why do we put the best locks on the front door and leave the back door vulnerable? Make sure that you have the best locks that you can afford on ALL your doors and not just the one you enter and exit from most of the time. Burglars normally do not use the front doors or windows to a residence. Burglars use doors that are out of view from the street and from your neighbors. Use the following to protect your home from burglary and theft. You will find that many of the measures described in this section are inexpensive and can be accomplished by yourself. There may be some steps that require a professional to come into your home to assist in installing a project for you.

## KEY CONTROL

True security begins with key control. If you are moving into a new home or apartment, always have the locks changed or re-keyed. You don't want the previous owners or renters or someone else getting into your home with the previous keys.

Do not leave an "emergency" key under the door mat, on top of the door, or any other place where someone may easily have access to your home. Never leave your name on your keys as they will be a welcome invite to a burglar if they should happen to find your keys.

## DOORS

Make sure outside doors and door frames are solid, made of 1 3/4" metal or hardwood. All exterior doors should have good locks and a deadbolt with a minimum 1" throw. Use the locks at all times, even when you are leaving for just a few minutes. Make sure that if there is a window in the door, the window is at least 40" from the position of the lock on the inside in case the burglar smashes the window to try and reach the lock. If there is a window within 40", a double cylinder lock is recommended, so that a key is used from either side of the door.

SINGLE CYLINDER



DOUBLE CYLINDER





## GLASS DOORS

Secure patio doors with sliding glass doors with commercially available bars or locks or put a wooden dowel or metal bar in the track portion of the sliding door to secure. Sliding glass doors present a major security problem if they do not have proper locks and if special steps are not taken to prevent the removal of the door.

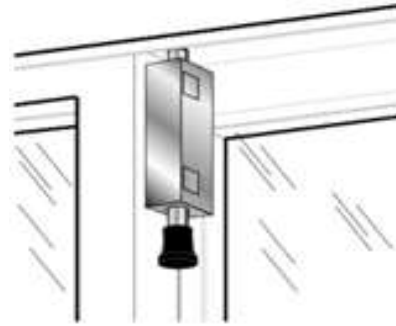

A sliding glass door is lifted into position when installed and must be lifted in the same way to remove it. To prevent the door from being removed after installation, it is recommended that a 1 1/4" pan head screw be used and installed into the top of the door frame at both ends and in the middle. These screws should be adjusted so that the door barely clears them when it is operated.

## WINDOWS-DOUBLE HUNG

Make sure all your windows have good locks, with special attention to the windows at ground level. Lock a double hung window by sliding a small headed bolt or nail through a hole drilled at a slight angle in a top corner of the inside sash and partway into the outside sash. The most effective protection for double hung windows is a key-locking security sash lock. If possible, mount the lock with two-inch wood screws.

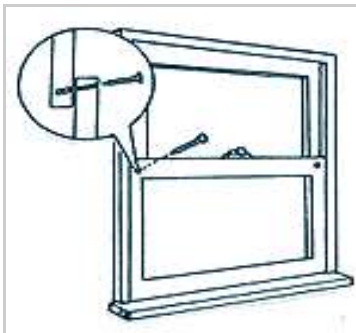

## BASEMENT WINDOWS

Make sure that basement windows are visible from the outside of the home and not covered by any bushes, trees, or other plantings. Burglar's use the plantings for concealment and have an ideal place to work unobserved. Bars may be placed on windows and caution must be used to assure that the bars are not placed to create a fire hazard. If bars are placed on windows, they should have a quick release mechanism in case of fires or other emergency.

## WINDOWS-CASEMENT

Casement windows are more secure than double hung windows. Casement windows are usually smaller and harder to climb through than double hung windows. A burglar usually has to smash this type of window to gain access due to the locking latch on the window. There are locks that can be purchased from the local hardware store to secure the casement window even further.

## GARAGE DOORS

The interior door leading to the home from an attached garage should be considered an exterior door and should be dead bolted, solid core, and as secure as the front door. Make sure that your garage door is closed and locked at all times, even if you are going away for a few minutes. Criminal's look for opportunities at all times and will enter the garage and take anything in just those few minutes that you are gone. Garage doors that do not have door openers should be secured by a good quality padlock. The most common type of assault on a padlock is with a large bolt cutter. A padlock with 9/32nd inch shackle and stainless steel offers the best in security. If there is an entry door to the garage, make sure that it is made of steel and has a proper deadbolt to it. Window's in the garage should also be secured by means previously described in this section.

Garage door openers have a new technology that changes the code each and every time it is used. Of the billions of codes that could be used to open a garage door, it would be virtually impossible for a burglar to figure out the code to enter. If your garage door does not have this technology, consider replacing it or change the code on your garage door.

Never leave your garage door opener in your vehicle. As stated many times before, a burglar is looking for an opportunity to enter your home or property. A garage door opener is a quick way of getting inside of your home to commit a crime.

## ALARMS

There are many home security systems on the market today. The alarms come in many different packages and price ranges. Do not depend solely on an alarm system to prevent crimes from happening to you and your home. Be sure to use the proper locking devices and other security measures in this handbook to add to your personal and home security.

## DOGS

There is controversy on the value of a dog to warn of a prowler. While a dog may or may not bark at an intruder, the very presence of a dog may discourage the intruder to find another target. Under no circumstances should a dog be the only security defense that you have. Police have seen burglars walk into a home with dogs and the dogs did not defend the home or confront the burglar. Secure your home so that the burglar will look for an easier target and you will not have to depend on your pet to protect your property.

# PROTECTING THE HOME'S EXTERIOR

Maintaining an appearance of occupancy, even when your home is vacant, is necessary to deter burglary attempts.

## LIGHTS

Exterior lighting is an excellent burglar deterrent. Lights with motion sensors and lights at each entry/exit door on the house and garage keep areas lit so that burglar's cannot hide in the dark. Make sure that these lights are properly positioned so that they are at the most advantageous to keep dark spots lit. There are maximums when it comes to lighting in the City of Oshkosh. Please refer to the city ordinances before installing lights that may interfere with your neighbors privacy.

## LANDSCAPING

In the Crime Prevention Program, Crime Prevention Through Environmental Design or CPTED, it is suggested that all bushes and flowers be trimmed to a height of no more than two (2) feet and trees be trimmed to no lower than at least six (6) feet. This trimming plan is advantageous for the home owner, neighbors, and police for observation of a potential prowler and to eliminate the ambush areas around the home.

Trees and other plants should be planted or cut away from windows and doors that obstruct a view from the street. Burglar's look for a place to hide and do their work such as overgrown vegetation.

If you decide to plant a tree's bushes, or flowers next to a house, garage, or fence, it is suggested that you plant a hostile plant variety so that it would be uncomfortable for a burglar or prowler to be next to such plantings. Suggestions of these plants are roses, barberry, or other plantings with thorns to make hiding in them almost impossible.

## FENCES

CPTED also suggests that instead of a privacy fence or one that you cannot see clearly through, you install a decorative fence made of aluminum or wrought iron. Not only is the fence more aesthetically pleasing, it also benefits the homeowner so that you can observe who is on the outside looking in and as neighbors or the police drive by, they can see who may be on the inside.

## GRAFFITI

One of the ongoing problems in the City of Oshkosh is graffiti. The Oshkosh Police Department takes graffiti very seriously and if you are a victim of graffiti, you should also take it seriously. Prompt reporting and removal of the graffiti is paramount in keeping our city graffiti free. Graffiti that is not removed only breeds other graffiti occurrences. If you recognize graffiti at your home or in your neighborhood, contact the police department immediately and report it. Oshkosh has a graffiti ordinance and the graffiti must be removed within 15 days after reporting it to the police. Failure to remove the graffiti within the specified time may result in a fine and the hiring of a professional cleaning agency to remove the graffiti, all which would be paid for by the home owner.

# PERSONAL PROTECTION

Although many of us may never experience the reality of an assault, it is never too late to be prepared for one. Preparation is the key. Stay alert at all times when either at home, place of business, or on vacation. Common sense and alertness are the best weapons in these situations.

## VEHICLES

Lock your vehicle at ALL times. Not just when the vehicle is parked, but when you are driving in your vehicle as well. This will prevent a car thief from attempting to gain access to your vehicle while it is stopped at a red light, stop sign, etc.

Remove all valuables from the vehicle at all times. If you cannot carry the item, place it in the trunk of the vehicle. A thief is looking for an easy target and in as fast as a few seconds, a thief can look in your vehicle, see your valuables, break the window, grab your property, and leave.

When driving, do not leave your property such as purses, laptops, or other valuable on the passenger seats of your vehicle. Once again, in as fast as a few seconds, a thief can smash and grab your property. Place your valuable on the front passenger floor or on the back floor.

If you are parking your vehicle in a lot, park as close to the building as possible and nearest an entrance/exit. Also, park under a light or as close to one as possible. This way if night comes, you will be able to see if anyone is around your vehicle.

When returning to your vehicle, have your keys in hand prior to leaving the building, and walk quickly to your vehicle in the middle of the lane. This is to avoid someone grabbing you if you are walking too close to a parked vehicle. Assaults have occurred while the perpetrator is hiding behind a vehicle. Some vehicles have a security feature with the automatic doors locks that once you press the button, the lights inside the vehicle turn on. Make a quick visual check inside the vehicle before entering. Once inside the vehicle, lock your doors again and leave the lot as soon as possible.

If you believe that someone is following you from the building and you feel unsecure, STOP, TURN TOWARD THE SUBJECT, STARE, AND YELL "WHAT DO YOU WANT?!" Hold this stare for 5-10 seconds. Show an assertive attitude with your head held high and your shoulders back. Turn back around and walk quickly with purpose to your vehicle or to an open business. Call 911 if you continue to feel uneasy.

Do not take the same route home each day and at the same time. Vary your route and the times that you may leave. Criminals look for patterns and once they know your routine and schedule, you become an easier target.

Never pick up hitchhikers.

Keep your car in good working condition to avoid breakdowns.

Always carry an emergency kit that includes a first aid kit, blankets, flashlight, and a 72 hour supply of food and water.

## PERSONAL PROTECTION (CONT)

### WALKING/RUNNING

Walking and running are great ways to keep in shape. Although this is your intent, someone else may be targeting you as you are exercising.

Choose busy streets and avoid passing vacant lots, alleys, or deserted sites. At night, stick to a well lit area or walk/run with someone.

Know the neighborhoods where you will be walking/running.

If walking to or from work, the store, or some other place, carry your belongings (i.e. purse, etc.) close to your body and keep a firm grip on it. Do not place the strap of a purse across your body or you may be injured more severely if you are pulled down by someone grabbing the strap. Carry your wallet in your front pocket.

Don't overload your arms and hands with items and avoid wearing shoes that are restrictive.

Carry an alarm type device in case of an emergency.

### HOME

All homeowners should have a way of seeing who may be at the door. Whether it is a window or a door viewer, you should know who it is before answering the door.

**DO NOT ALLOW STRANGERS IN YOUR HOME.** Many crimes take place in the victim's home. Burglar's, robbers, and rapists enter a home in just this manner. If you did not call for a repair person and someone claim's to be a repair person, ask to see identification and ask what their business is. You do not need to let them in even after they show ID.

If you have the slightest doubt, ask for a number or call the police and report a suspicious person.

If there is a claim from someone that there is an emergency and they want to use a phone, tell the person to wait outside while you call from inside your home.

### EMERGENCY NUMBERS

Make sure that all family members know the emergency numbers and when it is ok to call 911 in an actual emergency.

If you have a babysitter, let them know what your address is in case they need to call for emergency services and the address and phone number where you will be if there is an emergency at home.

### BURGLAR IN THE HOME

If there is a burglar in the home, do not go looking for a confrontation. If you discover a door or window that is open or broken, call 911 immediately and wait at a neighbor's house.

Despite all precautions that you may have taken to secure your home, a burglar may gain entry while you are in the house. If this occurs, expect the burglar to be in a frightened state of mind, perhaps desperate. Stay calm. If you have not seen the burglar face to face, lock the door of the room that you are in and call 911 if

If you have not seen the burglar face to face, go to a room in the house that has a door lock and lock the door of the room that you are in and place something heavy in front of the door. Call 911 if you have a phone. If not, begin making noise by moving things around or yell out for the police. This may scare the prowler out of the home. If you can safely escape this room, do so via the window, go to a neighbors and call the police.

If you do come face to face with a burglar, try to remain calm and speak in a normal voice. A frightened burglar may become aggressive with you if you are armed with a weapon. If you have a chance to escape, do so and yell for the police. If you do not have time to escape, never struggle with a burglar unless you are clearly in danger of physical harm. If you are forced to defend yourself, do whatever is necessary to stop the attack or assault.

You may also make one room in the home a “panic room.” This room would have solid core doors, a dead-bolt, and a phone to call police. You should be safe in this room until the police arrive.

\*\*\*Remember to never struggle with a burglar unless it is as a last resort to protect yourself or another person in the home. It is at that time that you may use any force necessary to stop the threat against you another person.

## VACATIONS

When you go on vacation, do you think about a crime happening to you when you reach your destination? If not, now is the time to think about it and take some useful steps to have a safe and enjoyable vacation.

As stated before, let someone who you trust know where you are going, for how long and someone that will look after your place.

In the airport, do not leave your luggage unattended. Keep an eye on the luggage at all times.

If you are not alone, go with someone when you are exploring the airport or to use the restroom.

When arriving at a hotel, check where the nearest exit or safe areas are in case of an emergency and make sure that all in your party know the evacuation plans and they know where to meet.

Ask the hotel about proper securement of your valuables such as an in-room safe. Do not leave money or other valuables in your hotel room.

When exploring your vacation destination, do not go it alone. Have someone with you at all times. Kids should always be under the watch of an adult. It is best to go in a large group where you have safety in numbers. If you need to split your group up, designate a meeting place and time. If you have cell phones, make sure that they are charged and can be used while on vacation.

Do not display expensive jewelry, cameras, video recorders, etc. while walking around. This is an open invitation to the criminal. Try not to look as a tourist.

Remember, a criminal is looking for that one opportunity to commit their crime. Your vacation should be fun and stress free. Use common sense and practice the personal security steps above and you will have a enjoyable vacation.

# PRESCRIPTION MEDICATIONS

One of the up and coming crimes in the area is the theft and sale of prescription medications. Although it is not a new criminal concept, it is one of the most prevalent that is being observed and investigated.

Prescription medications are readily available to the thief who will take these medications and can sell them on the street or to their family/friends and make a profit. The thief is usually known to the prescription holder, such as a friend or relative.

The prescription holder should maintain security of the medication at all times and know the amount of the medication that is remaining. The prescription holder should keep track of the medication that is used and periodically count the medicine remaining. If someone was to notice medication missing from them, they should report it to the police immediately. The prescription should be kept in a place that is secure, such as a lock box or medicine chest that can be accessed only by the prescription holder.

To make sure that you are secure when your prescription is either completely used, not in use, or expired, follow these steps:

Remove all identifiable information from the pill bottle before discarding.

Do not discard the medication in the toilet or the trash. The medication can actually contaminate the drinking water.

Save the unused or expired medication and drop it in the prescription medication drop box located at the Oshkosh Police Department and the police departments of Appleton, Fond du Lac, Neenah and the Town of Menasha.

\*Do not dispose of prescription medications in the toilet, down the drain or in the garbage. 80% of waterways in the United States have traces of prescription medications. Wildlife in these areas are also exposed to the prescription medications while taking in water. Use the drug drop box chute and don't pollute!





## NEIGHBORHOOD WATCH

One of the most effective and least expensive programs in crime prevention is the Neighborhood Block Watch Programs. This program does not take much time, effort, or money, if any, yet reduces crime in any area that has the program, especially burglary.

Sir Robert Peel, the founder of the modern day police force, developed nine policing concepts that all police departments, even today, are guided by. One of these concepts is, "The Public are the Police and the Police are the Public." Simply stated, we are all working together in crime prevention. It is the responsibility of all citizens to report all suspicious activity and crimes that are observed or heard about to the police.

To organize a Neighborhood Watch, begin by contacting your neighbors and let them know that you are beginning a neighborhood watch in your area. Make a list of the neighbors that you have contacted and their personal information, such as address and phone number. Next, schedule an initial meeting at a central location, which could be your house, a local park, or other meeting place.

At the meeting, you and your neighbors can identify problems that exist in your area and you can set a strategy as to how these problems should be handled. You may invite the Crime Prevention Officer or District Officer to this initial meeting to assist in how to handle the problems in the area. You may select a block watch captain (if not already assigned) and a co-captain. At this meeting, you and the neighborhood can also write down goals for the area, such as a neighborhood clean up project, a yearly neighborhood party celebrating your accomplishments, or any other project that you deem necessary.

Continue these meetings with your neighbors and continue to identify problems that may start or continue. One of the factors of a neighborhood block watch that fails is lack of communication. Once communication breaks down and neighbors no longer share valuable information with each other, the block watch no longer can succeed.

Quarterly meetings are held for each district and you will be notified as to the date, time and location of the meetings. At the meetings, District Sergeants, Officers and special guests will be in attendance. Watch for the notifications and we hope to see you at the next quarterly meeting.

It is also one of the bigger misconceptions that if there is no crime in an area, a block watch is either not needed or cannot remain viable. This is not true. A strong, cohesive neighborhood is the best deterrent to crime. Criminals need the opportunity to commit their criminal acts. By taking the criminals opportunity away, they go to a weaker area of the city, or better yet, out of the city to attempt to commit the crimes where they know opportunities are abundant.

Take a positive step for your neighborhood and get to know your neighbors and share information with them to make your neighborhood safe. Report to the police street lamps that are not working, vacant lots with debris, and other problems that make your neighborhood say "We don't care."

It is the Oshkosh Police Departments hope that the Neighborhood Watch Program remain a strong part of Crime Prevention in the City of Oshkosh and that this program will assist in the reduction or elimination of crime involving your homes and businesses in your area. We Thank You for being involved in this very important program.



# OSHKOSH POLICE PHONE NUMBERS

EMERGENCY	911
NON-EMERGENCY	236-5700
ADMINISTRATIVE	236-5720
COURT OFFICER	236-5716
CRIME PREVENTION	236-5742
INVESTIGATIVE SERVICES	236-5725
JUVENILE UNIT	236-5725
RECORDS DIVISION	236-5731
CRIME STOPPERS	(920) 231-8477

Phone numbers for individual officers can be found at [www.oshkoshpd.com](http://www.oshkoshpd.com). Go to the Team Policing tab and a map will appear. Once there, find your neighborhood and click once. Your reporting area officer's picture will appear with their email and phone number. Other officers will also appear if you click on the team links.

## **OSHKOSH PD WEB SITE**

You can also find specialized units on the Oshkosh Police website, along with news and information on the department. If you have a community event that you would like placed on the website, please contact the police department at 236-5700. Thank you!



# OPERATION I.D.

Complete this section by placing a description of the valuable and placing the serial number and model number in the proper area. Remember to mark your item by using your drivers license number (i.e. for Wisconsin DL numbers WI XXXX-XXXX-XXXX-XX.) If you do not have a Wisconsin DL or another state DL, do not use your social security number. Use a unique number only known to you or obtain a Wisconsin I. D. card.

**ITEM DESCRIPTION**

**SERIAL #/MODEL #**

1. \_\_\_\_\_
2. \_\_\_\_\_
3. \_\_\_\_\_
4. \_\_\_\_\_
5. \_\_\_\_\_
6. \_\_\_\_\_
7. \_\_\_\_\_
8. \_\_\_\_\_
9. \_\_\_\_\_
10. \_\_\_\_\_
11. \_\_\_\_\_
12. \_\_\_\_\_
13. \_\_\_\_\_
14. \_\_\_\_\_
15. \_\_\_\_\_
16. \_\_\_\_\_
17. \_\_\_\_\_
18. \_\_\_\_\_
19. \_\_\_\_\_
20. \_\_\_\_\_
21. \_\_\_\_\_



## WARNING SIGNS OF A DRUG HOUSE

### What to watch for:

High vehicle and/or pedestrian traffic. In the home for less than 10 minutes.

Traffic may be recurring at certain times of the month  
(i.e. pay day and the first day of the month)

People bringing valuables in the home and leave empty handed.

People may sit in a vehicle for a while after leaving the residence or one person may stay in the vehicle while the other visits.

Suspicious activity this is obvious such as drug exchanges between people, untidy property, or other drug paraphernalia lying about.

Regular activity at late hours of the night. (Both cocaine and methamphetamine users tend to stay up all night.)

**IN AN EMERGENCY, CALL 911. TO REPORT CRIMINAL OR SUSPICIOUS ACTIVITY, CALL (920) 236-5700 OR YOU CAN E-MAIL YOUR DISTRICT OFFICER AT [www.oshkoshpd.com](http://www.oshkoshpd.com) and click on TEAM POLICING.**